

4

3

2

1

B

B

A

A

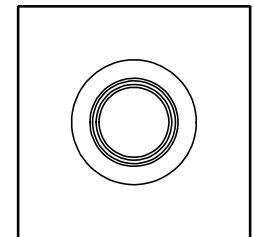
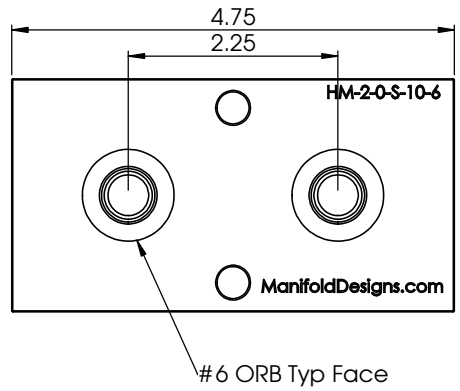
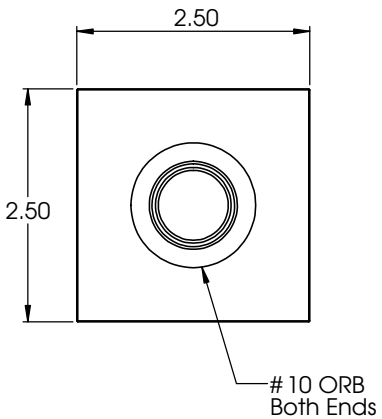
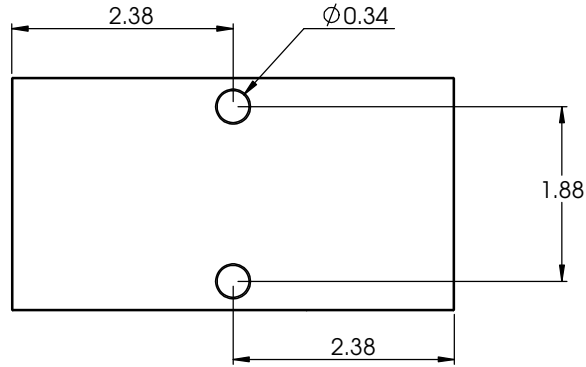

PROPRIETARY AND CONFIDENTIAL
 THE INFORMATION CONTAINED IN THIS DRAWING IS THE SOLE PROPERTY OF <INSERT COMPANY NAME HERE>. ANY REPRODUCTION IN PART OR AS A WHOLE WITHOUT THE WRITTEN PERMISSION OF <INSERT COMPANY NAME HERE> IS PROHIBITED.

		UNLESS OTHERWISE SPECIFIED:	NAME	DATE	TITLE: Header Manifold
		DIMENSIONS ARE IN INCHES	DRAWN		
		TOLERANCES:	CHECKED		
		FRACTIONAL ±	ENG APPR.		
		ANGULAR: MACH ± BEND ±	MFG APPR.		Q.A.
		TWO PLACE DECIMAL ±	COMMENTS:		
		THREE PLACE DECIMAL ±			SIZE DWG. NO. REV
		INTERPRET GEOMETRIC TOLERANCING PER:			B HM-2-0-S-10-6
		MATERIAL			SCALE: 1:1 WEIGHT: SHEET 1 OF 1
		6061			
NEXT ASSY	USED ON	FINISH			
		Black Anodize			
APPLICATION		DO NOT SCALE DRAWING			

4

3

2

1