

4

3

2

1

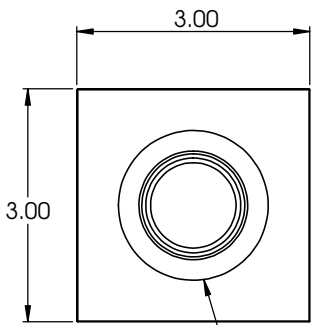

16 ORB
Both Ends

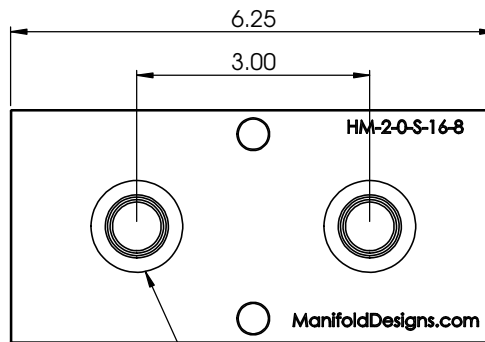
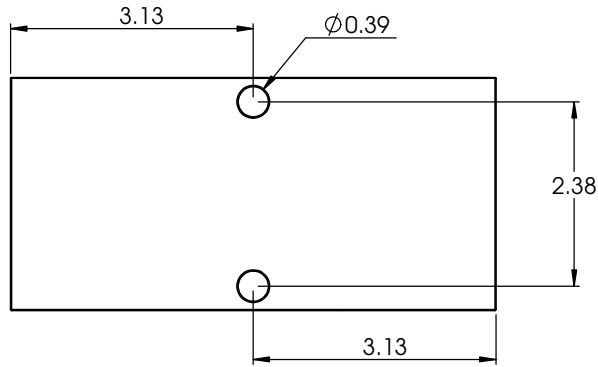

8 ORB Typ Face

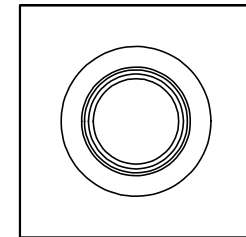

Manifold Design & Production Inc.

PROPRIETARY AND CONFIDENTIAL

THE INFORMATION CONTAINED IN THIS DRAWING IS THE SOLE PROPERTY OF <INSERT COMPANY NAME HERE>. ANY REPRODUCTION IN PART OR AS A WHOLE WITHOUT THE WRITTEN PERMISSION OF <INSERT COMPANY NAME HERE> IS PROHIBITED.

		UNLESS OTHERWISE SPECIFIED:	NAME	DATE	TITLE: Header Manifold
		DIMENSIONS ARE IN INCHES TOLERANCES: FRACTIONAL: ± ANGULAR: MACH ± BEND ± TWO PLACE DECIMAL ± THREE PLACE DECIMAL ±	DRAWN		
		INTERPRET GEOMETRIC TOLERANCING PER:	CHECKED		
		MATERIAL 6061	ENG APPR.		
NEXT ASSY	USED ON	FINISH Black Anodize	MFG APPR.		SIZE B
APPLICATION		DO NOT SCALE DRAWING	Q.A.		DWG. NO. HM-2-0-S-16-8
			COMMENTS:		REV
					SCALE: 1:1 WEIGHT:
					SHEET 1 OF 1

4

3

2

1

B

B

A

A